

EX. BLOCK "G"
CITY OF AVON
04-00-003-101-494
59.47 ACRES

EX. BLOCK "F"
CITY OF AVON
04-00-004-103-031
7.06 ACRES

CITY OF AVON
04-00-004-103-030
8.96 ACRES

EX. BLOCK "E"

PILOT TRAVEL CENTERS LLC
04-00-004-103-028
INST. #20070229337
3.2586 ACRES (VACANT LAND)

EX. BLOCK "C"
CITY OF AVON
04-00-003-101-492
8.08 ACRES (RECORD)
7.72± ACRES (CALC.)
PARCEL 4
7.72± ACRES

EX. BLOCK "D"
CITY OF AVON
04-00-003-101-493
11.31± ACRES

AVON RECREATION COMPLEX SUBDIVISION
VOLUME 95, PAGES 78-84

PARCEL 1
8.54± ACRES

PARCEL 2
1.09± ACRES (ON DOME SITE)
0.36± OF AN ACRE (ON YMCA SITE)
1.45± ACRES

PARCEL 3
1.68 ACRES

105,800 S.F. DOME STRUCTURE

HARD STRUCTURE
8,200 S.F.

YMCA
2010 RECREATION
LANE

RECREATION LANE

GENERAL PARKING AREA

EX. BLOCK "A"

BASEBALL
BOULEVARD

EX. BLOCK "B"

CITY OF AVON
04-00-003-101-491
9.71 ACRES

TABLE OF CURVATURE						
CURVE	LENGTH	RADIUS	CHORD	BEARING	TANGENT	DELTA
C1	408.41'	260.00'	367.70'	S 45°00'00" E	260.00'	90°00'00"
C2	241.38'	146.50'	214.99'	N 47°12'07" W	158.22'	94°24'15"

NOTE:
1. PLEASE NOTE THIS DRAWING IS FOR GENERAL DISCUSSION PURPOSES ONLY. THIS PLAN REPRESENTS A CONCEPTUAL PLAN AND IS SUBJECT TO REVIEWING AGENCY COMMENTS AND FINAL DESIGN MODIFICATIONS.

TABLE OF LINES		
LINE	BEARING	DISTANCE
L1	"DUE NORTH"	12.00'
L2	"DUE EAST"	10.00'
L3	N 33°41'27" E	36.06'
L4	N 00°11'47" W	39.70'
L5	S 18°06'12" E	18.61'
L6	"DUE EAST"	10.00'
L7	"DUE SOUTH"	12.00'

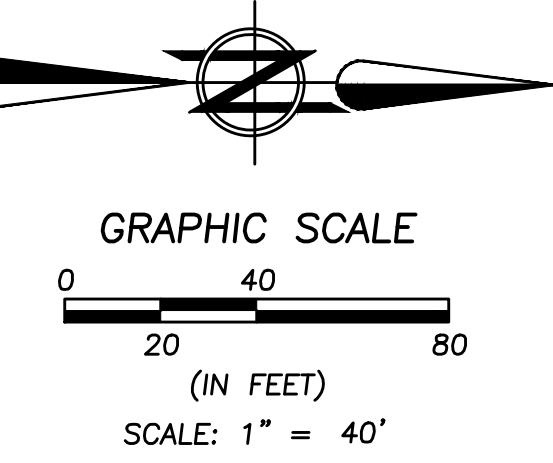

J:\AVON\07241-007L Athletic Center\BRAMHALL\Athletic Center Concept Plan and Lot Split.dwg, Plotted: Sep 11, 2013 - 10:18am

DATE	BY	DESCRIPTION
09-11-2013	MCB	ISSUE TO CITY FOR REVIEW

DRAWN BY: SJM
CHECKED BY: APA

801 MOORE ROAD AVON, OHIO 44011
(440) 934 - 7878 (440) 934 - 7879 FAX

PREPARED FOR:

CITY OF AVON
36080 CHESTER ROAD AVON, OHIO 44011
PH. (440) 937-7800 FAX. (440) 937-7824

SSA DELAWARE LLC
2.4694 ACRES (VACANT LAND)

**FRENCH CREEK RECREATION AREA
POTENTIAL AVON ATHLETIC CENTER CONCEPT
PLAN AND LOT SPLIT/ SUBDIVISION No. 2
CITY OF AVON, COUNTY OF LORAIN, STATE OF OHIO**

SHEET
2 OF 2
JOB NO.
07-2411-007L